

8VL and 8VLX

8" Submersible Non-Clog Wastewater Pump
Standard (8VL) and Explosion-Proof (8VLX)



THE MYERS 8VL SUBMERSIBLE NON-CLOG SEWAGE PUMPS ARE DESIGNED ESPECIALLY FOR HIGH FLOW APPLICATIONS SUCH AS: Large municipal lift stations, treatment plants, transfer stations and dewatering. A quick removal type rail system is available to simplify installation and maintenance. The 8VL's ability to handle solids up to 4 inches in diameter and 3 available motor speeds make it ideal for most high flow wastewater applications. For more information, contact your Myers distributor or the Myers Ohio sales office at 419-289-1144.

ADVANTAGES BY DESIGN

HIGH EFFICIENCY HYDRAULIC DESIGN CUTS PUMPING COSTS AND EXTENDS LIFE OF FLUID END COMPONENTS.

- Two-vane, rounded port impellers handle solids with ease at high operating efficiencies.
- Modified, constant velocity volute offers quiet operation, low radial loads over extended portion of performance curve.

DURABLE MOTOR WILL DELIVER MANY YEARS OF RELIABLE SERVICE

- Oil-filled motor and seal cavity for maximum heat dissipation and continuous bearing lubrication.
- Heat sensor thermostats imbedded in windings protect motor from overheat conditions.
- Seal leak probes warn of moisture entry; helps prevent costly motor burn-out.

PRODUCT CAPABILITIES

Capacities To	3875 gpm	14667 lpm
Heads To	170 ft.	51.8 m
Solids Handling (dia.)	4 in.	101.6 mm
Liquids Handling	raw, unscreened sewage, drain water, effluent	
Intermittent Liquid Temp.	up to 140°F	up to 60°C
Winding Insulation Temp. (Class H)	355°F	180°C
Available Motors	1750 RPM: 75, 100, 125 hp, 3 ph 460 & 575 volts, 60 Hz 1150 RPM: 30, 40, 50 hp, 3 ph 230, 460, 575 volts, 60 Hz 60 hp, 3 ph 460 & 575 volts, 60 Hz 870 RPM: 15, 20, 25 hp, 3 ph 208, 230, 460 & 575 volts, 60 Hz	
Std. Third Party Approvals	CSA	
Optional Approvals	FM Class 1, Groups C & D	
Acceptable pH Range	6-9	
Specific Gravity	9-1.1	
Viscosity	28-35 SSU	
Horizontal Discharge	8 in.	203.2 mm

NOTE: Consult factory for applications outside of these recommendations.

Construction Materials	
Motor Housing, Seal Housing, Cord Cap, Volute Case	cast iron, Class 30, ASTM A48
Enclosed 2-Vane Impeller	ductile iron, Class 65 ASTM A536
Power, Control Cords	25 SOOW
Double Tandem Mechanical Seals	Std. - carbon & ceramic Opt. - lower tungsten carbide
Pump, Motor Shaft	416 SST
Fasteners	300 Series SST
Case Wear Ring	bronze

WHERE INNOVATION MEETS TRADITION

Myers[®]

Pentair Water

pump performance curve

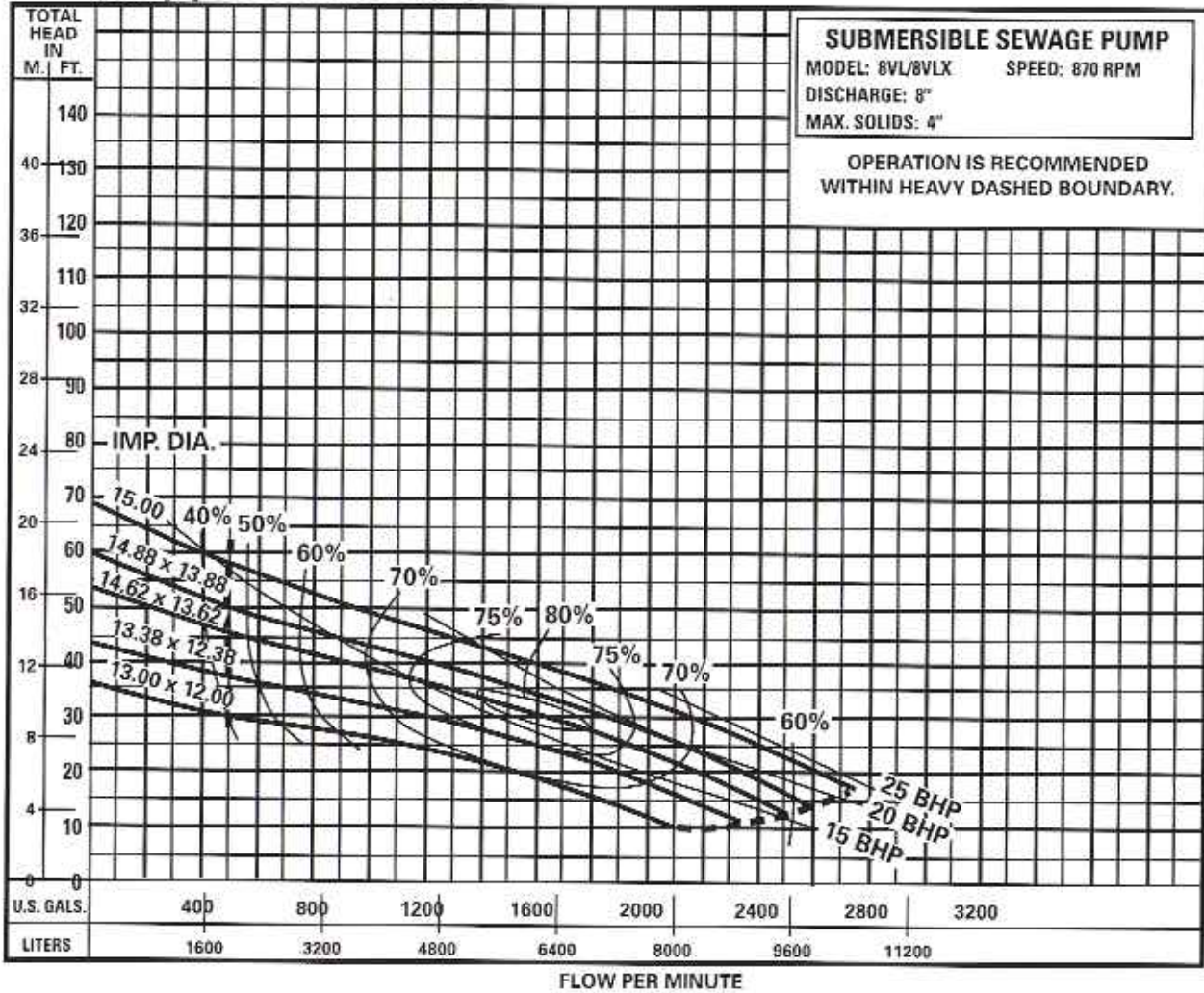

Available Models		Motor Electrical Data												
Standard	Explosion Proof	HP	Volts	Phase	Hz	Start Amps	Run Amps	Service Factor Amps	Run KW	Service Factor KW	Start KVA	Run KVA	NEC Code Letter	Service Factor
8VL150M8-03	8VLX150M8-03	15	200	3	60	334	53.4	61.2	13.4	15.8	116	18.5	J	1.2
8VL150M8-23	8VLX150M8-23	15	230	3	60	290	46.4	53.2	13.4	15.8	116	18.5	J	1.2
8VL150M8-43	8VLX150M8-43	15	460	3	60	145	23.2	26.6	13.4	15.8	116	18.5	J	1.2
8VL150M8-53	8VLX150M8-53	15	575	3	60	116	18.6	21.3	13.4	15.8	116	18.5	J	1.2
8VL200M8-03	8VLX200M8-03	20	200	3	60	334	67.2	78.5	17.6	20.9	116	23.2	G	1.2
8VL200M8-23	8VLX200M8-23	20	230	3	60	290	58.4	68.3	17.6	20.9	116	23.2	G	1.2
8VL200M8-43	8VLX200M8-43	20	460	3	60	145	29.2	34.1	17.6	20.9	116	23.2	G	1.2
8VL200M8-53	8VLX200M8-53	20	575	3	60	116	23.3	27.3	17.6	20.9	116	23.2	G	1.2
8VL250M8-03	8VLX250M8-03	25	200	3	60	501	84.2	101.0	21.2	26.4	175	29.2	H	1.2
8VL250M8-23	8VLX250M8-23	25	230	3	60	436	73.2	87.8	21.2	26.4	175	29.2	H	1.2
8VL250M8-43	8VLX250M8-43	25	460	3	60	218	36.8	44.0	21.2	26.4	175	29.2	H	1.2
8VL250M8-53	8VLX250M8-53	25	575	3	60	174	29.3	35.1	21.2	26.4	175	29.2	H	1.2

Motor Efficiencies and Power Factor									
		Motor Efficiency %				Power Factor %			
HP	Phase	Service Factor Load	100% Load	75% Load	50% Load	Service Factor Load	100% Load	75% Load	50% Load
15	3	85.0	83.5	81.5	75	74.5	72.5	68.0	59.0
20	3	85.5	85.0	83.5	80	77.0	75.5	72.5	66.0
25	3	85.0	88.0	87.0	83	75.3	72.7	68.5	59.5

pump performance curve

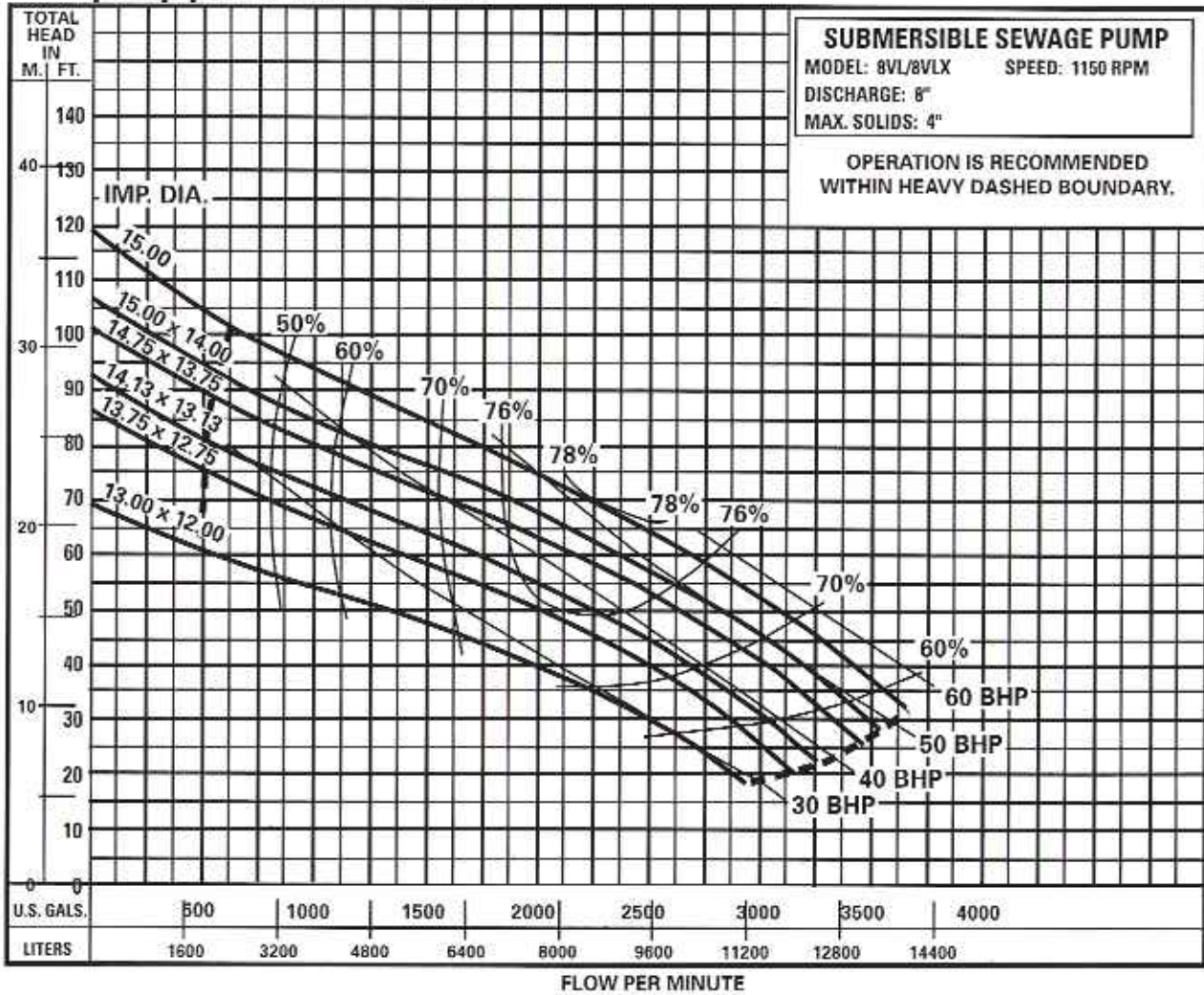

Available Models		Motor Electrical Data												
Standard	Explosion Proof	HP	Volts	Phase	Hz	Start Amps	Run Amps	Service Factor Amps	Run KW	Service Factor KW	Start KVA	Run KVA	NEC Code Letter	Service Factor
8VL300M6-23	8VLX300M6-23	30	230	3	60	580	88.4	106.0	26.0	31.2	230	35.2	J	1.2
8VL300M6-43	8VLX300M6-43	30	460	3	60	290	44.2	53.0	26.0	31.2	230	35.2	J	1.2
8VL300M6-53	8VLX300M6-53	30	575	3	60	232	35.3	42.4	26.0	31.2	230	35.2	J	1.2
8VL400M6-23	8VLX400M6-23	40	230	3	60	580	110.4	132.5	34.3	41.2	230	44.0	G	1.2
8VL400M6-43	8VLX400M6-43	40	460	3	60	290	55.2	66.2	34.3	41.2	230	44.0	G	1.2
8VL400M6-53	8VLX400M6-53	40	575	3	60	232	44.2	53.0	34.3	41.2	230	44.0	G	1.2
8VL500M6-23	8VLX500M6-23	50	230	3	60	417	138.0	165.6	42.6	51.4	290	63.3	G	1.2
8VL500M6-43	8VLX500M6-43	50	460	3	60	363	69.0	82.8	42.6	51.4	290	63.3	G	1.2
8VL500M6-53	8VLX500M6-53	50	575	3	60	290	55.2	66.2	42.6	51.4	290	63.3	G	1.2
8VL600M6-43	8VLX600M6-43	60	460	3	60	405	82.7	101.0	51.4	62.7	323	65.9	F	1.2
8VL600M6-53	8VLX600M6-53	60	575	3	60	324	66.2	80.8	51.4	62.7	323	65.9	F	1.2

Motor Efficiencies and Power Factor									
HP	Phase	Motor Efficiency %				Power Factor %			
		Service Factor Load	100% Load	75% Load	50% Load	Service Factor Load	100% Load	75% Load	50% Load
30	3	86	86	84	79.0	73.9	73.8	67.8	55.0
40	3	87	87	86	82.5	78.0	78.0	73.8	65.2
50	3	87	88	87	85.0	78.0	77.5	77.5	68.0
60	3	86	87	87	86.0	78.0	78.0	78.0	72.5

pump performance curve

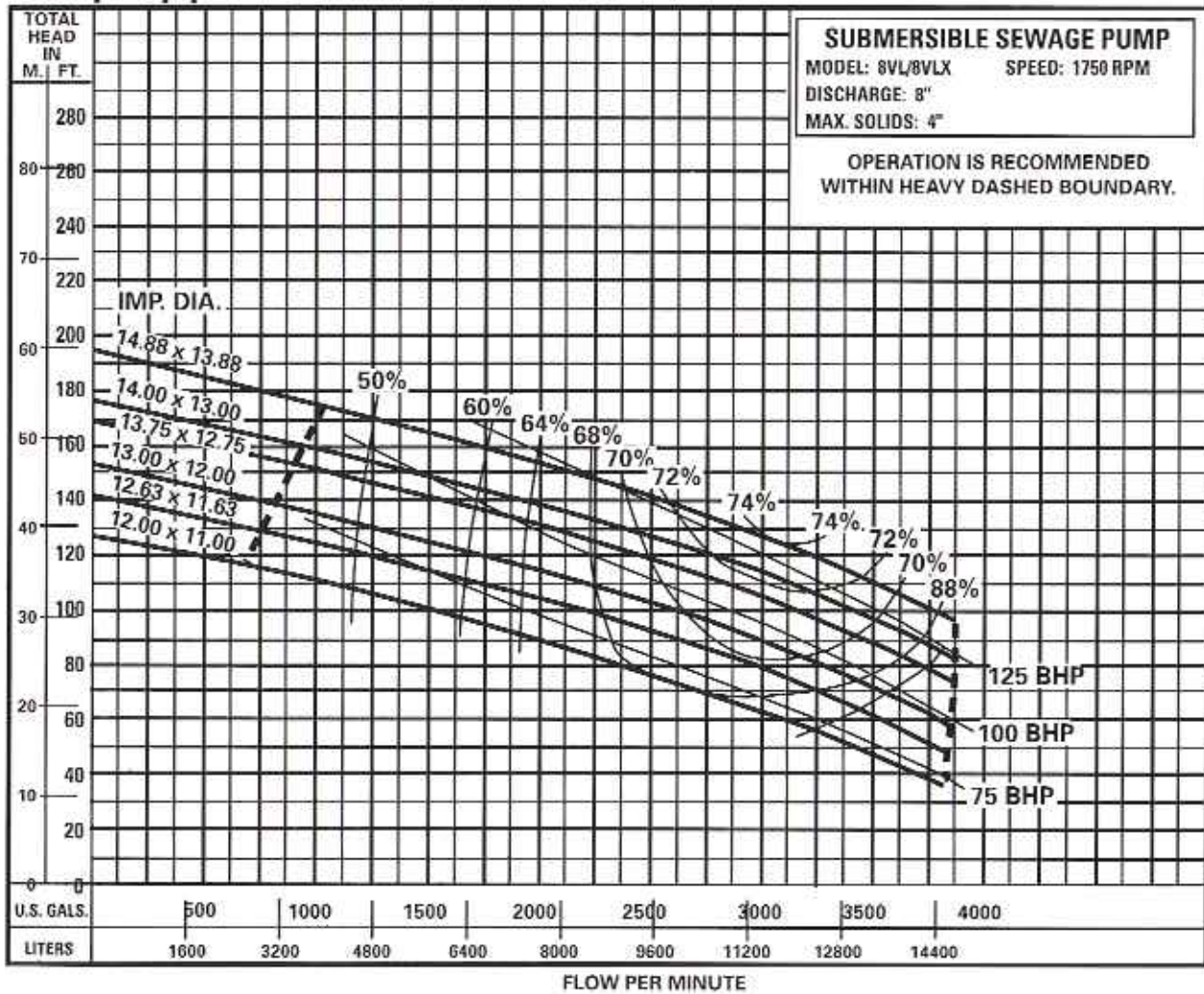

Available Models		Motor Electrical Data												
Standard	Explosion Proof	HP	Volts	Phase	Hz	Start Amps	Run Amps	Service Factor Amps	Run KW	Service Factor KW	Start KVA	Run KVA	NEC Code Letter	Service Factor
8VL750M4-43	8VLX750M4-43	75	460	3	60	540	101.8	122.2	64.2	77.0	430	81.0	G	1.2
8VL750M4-53	8VLX750M4-53	75	575	3	60	432	81.4	97.8	64.2	77.0	430	81.0	G	1.2
8VL1000M4-43	8VLX1000M4-43	100	460	3	60	725	129.0	155.0	85.7	103.0	578	103.0	G	1.2
8VL1000M4-53	8VLX1000M4-53	100	575	3	60	580	103.2	124.0	85.7	103.0	578	103.0	G	1.2
8VL1250M4-43	8VLX1250M4-43	125	460	3	60	725	165.0	175.0	108.0	115.0	578	131.0	G	1.1
8VL1250M4-53	8VLX1250M4-53	125	575	3	60	580	132.0	140.0	108.0	115.0	578	131.0	G	1.1

Motor Efficiencies and Power Factor									
HP	Phase	Motor Efficiency %				Power Factor %			
		Service Factor Load	100% Load	75% Load	50% Load	Service Factor Load	100% Load	75% Load	50% Load
75	3	87.1	87.1	87.3	83.5	79.1	79.2	79.1	79
100	3	87.0	88.0	87.0	84.0	83.4	83.4	79.2	77
125	3	86.0	86.3	88.0	87.0	82.5	82.0	80.0	78

CABLE ENTRY SYSTEM

Cable jackets sealed with clamped, rubber grommet. Individual wires sealed with epoxy to prevent wicking in case of cable damage.

TERMINAL BOARD

Provides easy connections from power and control cables to stator. Allows voltage change in field on dual winding motors.

HEAVY 416 SST SHAFT

Reduces deflection from impeller radial loads. Tapered and keyed to accept impeller.

HEAT SENSOR ON MOTOR WINDING

Opens to de-energize motor starter if winding temperature reaches 150°C. Automatic reset.

MOTOR STATOR

Oil-filled for continuous lubrication of bearings and seals. Class H insulation.

UPPER AND LOWER BALL BEARINGS

DOUBLE TANDEM SHAFT SEALS

Protect motor, operate in clean oil.

HORIZONTAL DISCHARGE VOLUTE CASE

8" 125 lb. flange.

DUAL SEAL LEAK PROBES

Detect water in seal housing. Activates warning light in control panel.

BRONZE WEAR RING

Reduces by-pass leakage and wear. Replaceable to restore original running clearances and pump efficiencies.

PUMP OUT VANES

Help keep trash from seal, reduces pressure at seal faces.

HIGH EFFICIENCY IMPELLER

Two-vane, rounded port, non-clogging design. Passes 4" spherical solids.

DIMENSIONS

[] dimensions in mm

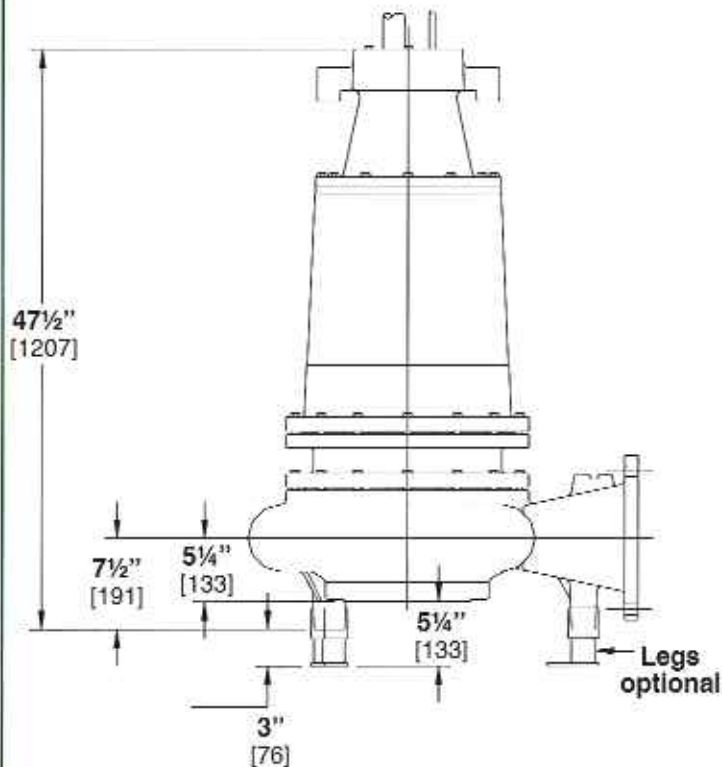
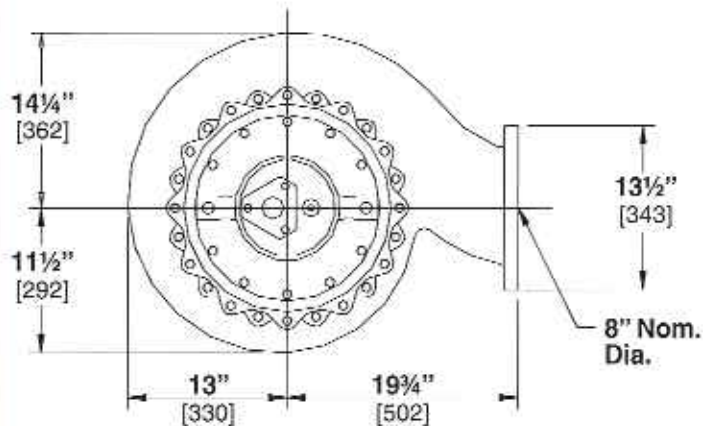

8VL and 8VLX

SPECIFICATIONS

PUMP MODEL - Pump shall be Myers Model Number 8VL / 8VLX Non-Clog Submersible Pump with 2 vane enclosed impeller. All openings in pump impeller and volute case to be large enough to pass a 4" diameter sphere. Discharge flange shall be eight (8) inch standard. The pump and motor assembly shall be FM listed for Class 1, Groups C and D explosion-proof service (8VLX only).

OPERATING CONDITIONS - Pump shall have a capacity of _____ GPM at a total head of _____ feet and shall use a _____ HP motor operating at _____ RPM.

MOTOR - Pump motor shall be of the sealed submersible type rated _____ HP at _____ RPM 60 Hertz. Motor shall be for three phase 200 volts _____, 230 volts _____, 460 volts _____ or 575 volts _____. Motor shall be NEMA B type.

Stator winding shall be of the open type with Class H insulation good for 180°C maximum temperature. Winding housing shall be filled with a clean high dielectric oil that lubricates bearings and seals and transfers heat from winding and rotor to outer shell. Air-filled motors which do not have the superior heat dissipating capabilities of oil-filled motors shall not be considered equal.

Motor shall have two heavy duty ball bearings to support pump shaft and take radial and thrust loads. Ball bearings shall be designed for 50,000 hours B-10 life. Stator shall be held in place by four (4) clamp rings on the upper end of the stator; each clamp ring shall be held by two (2) motor bolts.

A heat sensor thermostat shall be attached to and imbedded in the winding and be connected in series with the motor starter contactor coil to stop motor if temperature of winding is more than 302°F. Thermostat shall reset automatically when motor cools to safe operating temperature. Three heat sensors to be used on 3 phase motors. The common pump, motor shaft shall be of 416 stainless steel and shall be of tapered design.

SEALS - Motor shall be protected by two mechanical seals mounted in tandem with a seal chamber between the seals. Seal chamber shall be oil filled to lubricate seal face and to transmit heat from shaft to outer shell.

Seal faces shall be carbon and ceramic and lapped to a flatness of one light band. Lower seal faces shall be _____ carbide (optional).

A double electrode shall be mounted in the seal chamber to detect any water entering the chamber through the lower seal. Water in the chamber shall cause a red light to turn on at the control box. This signal shall not stop motor but shall act as a warning only, indicating service is required.

IMPELLER - The impeller shall be ductile iron and of the 2 vane non-clog enclosed type. Vane inlet tips shall be carefully rounded to prevent stringy material from catching in vanes. Pump-out vanes shall be used in front and back chamber. Impeller shall be dynamically balanced.

Impeller to be driven by stainless steel shaft key and impeller held in place with lock screw and washer on a tapered shaft. Impeller and motor shall lift off of case as a unit without disturbing discharge piping.

PUMP CASE - The volute case shall be cast iron and have a flanged center line discharge. Discharge flange shall be eight (8) inch standard with bolt holes straddling center line. Bronze wear ring to be pressed into case for guiding impeller neck and to prevent corrosion freeze up. Wear ring to be held from rotating by locking with stainless steel set screw in end of ring.

PUMP AND MOTOR CASTING - All castings shall be of high tensile cast iron and shall be treated with phosphate and chromate rinse. All fasteners shall be 302 stainless steel.

BEARING END CAP - Upper motor bearing cap shall be a separate casting for easy mounting and replacement.

POWER CABLES - Power cord and control cord shall be triple sealed. The power and control conductor shall be single strand sealed with epoxy potting compound and then clamped in place with rubber seal bushing to seal outer jacket against leakage and to provide for strain pull. A third sealing area shall be provided by a terminal board to separate the cable entry chamber from the motor chamber. Cords shall withstand a pull of 300 pounds to meet FM requirements.

Insulation of power and control cords shall be type SJOW/SJOW-A or SOOW. Both control and power cords shall have a green carrier ground conductor that attaches to motor frame.

8SM and 8SMX

8" Submersible Non-Clog Wastewater Pumps
Standard (8SM) and Explosion-Proof (8SMX) Construction



APPROVED
(8SMX only)



THE MYERS 8SM SUBMERSIBLE NON-CLOG SEWAGE PUMPS ARE DESIGNED ESPECIALLY FOR HIGH FLOW APPLICATIONS SUCH AS: large municipal lift stations, treatment plants, transfer stations and dewatering. A quick removal type rail system is available to simplify installation and maintenance. The 8SM's ability to handle solids up to 3 inches in diameter make it ideal for most high flow wastewater applications. For more information, contact your Myers distributor, or the Myers Ohio sales office at 419-289-1144.

ADVANTAGES BY DESIGN

HIGH EFFICIENCY HYDRAULIC DESIGN CUTS PUMPING COSTS AND EXTENDS THE LIFE OF THE PUMP

- Two-vane, rounded port impeller handles 3" solids with ease at high operating efficiencies.
- Produces high heads and flows

DURABLE MOTOR WILL DELIVER MANY YEARS OF RELIABLE SERVICE

- Class H Insulation.
- Continuous duty/VFD rated.
- Oil-filled motor for maximum heat dissipation and constant bearing lubrication.
- Internal thermal overload protection.
- Double tandem shaft seals prevent sewage from entering motor.
- Internal seal leak probes warn of moisture entry.
- Triple sealed power and control cables.

PRODUCT CAPABILITIES

Capacities To	2320 gpm	8800 lpm
Heads To	260 ft.	79 m
Solids Handling	3 in.	76 mm
Liquids Handling	raw unscreened sewage, drain water, effluent	
Intermittent Liquid Temp.	up to 140°F	up to 60°C
Winding Insulation Temp. (Class H)	356°F	180°C
Available Motors	1750 RPM 75, 100, 125 HP 460 & 575 volts 3 phase, 60 Hz	
Std. Third Party Approvals	CSA	
Optional Approvals	FM Class 1, Groups C & D (8SMX only)	
Acceptable pH Range	6 - 9	
Specific Gravity	.9 - 1.1	
Viscosity	28 - 35 SSU	
Discharge, Horizontal	8 in.	203.2 mm

NOTE: Consult factory for applications outside of these recommendations.

Construction Materials

Motor Housing, Seal Housing, Cord Cap and Volute Case	cast iron, Class 30 ASTM A48
Impeller	ductile iron, Class 65 ASTM A536
Power and Control Cord	25 ft. SOCW
Double Tandem Mechanical Seals	Std. - carbon & ceramic opt. - lower tungsten carbide
Pump, Motor Shaft	416 SST
Fasteners	300 Series SST
Case Wear Ring	bronze

WHERE INNOVATION MEETS TRADITION

Myers[®]

Pentair Water

PERFORMANCE CURVE

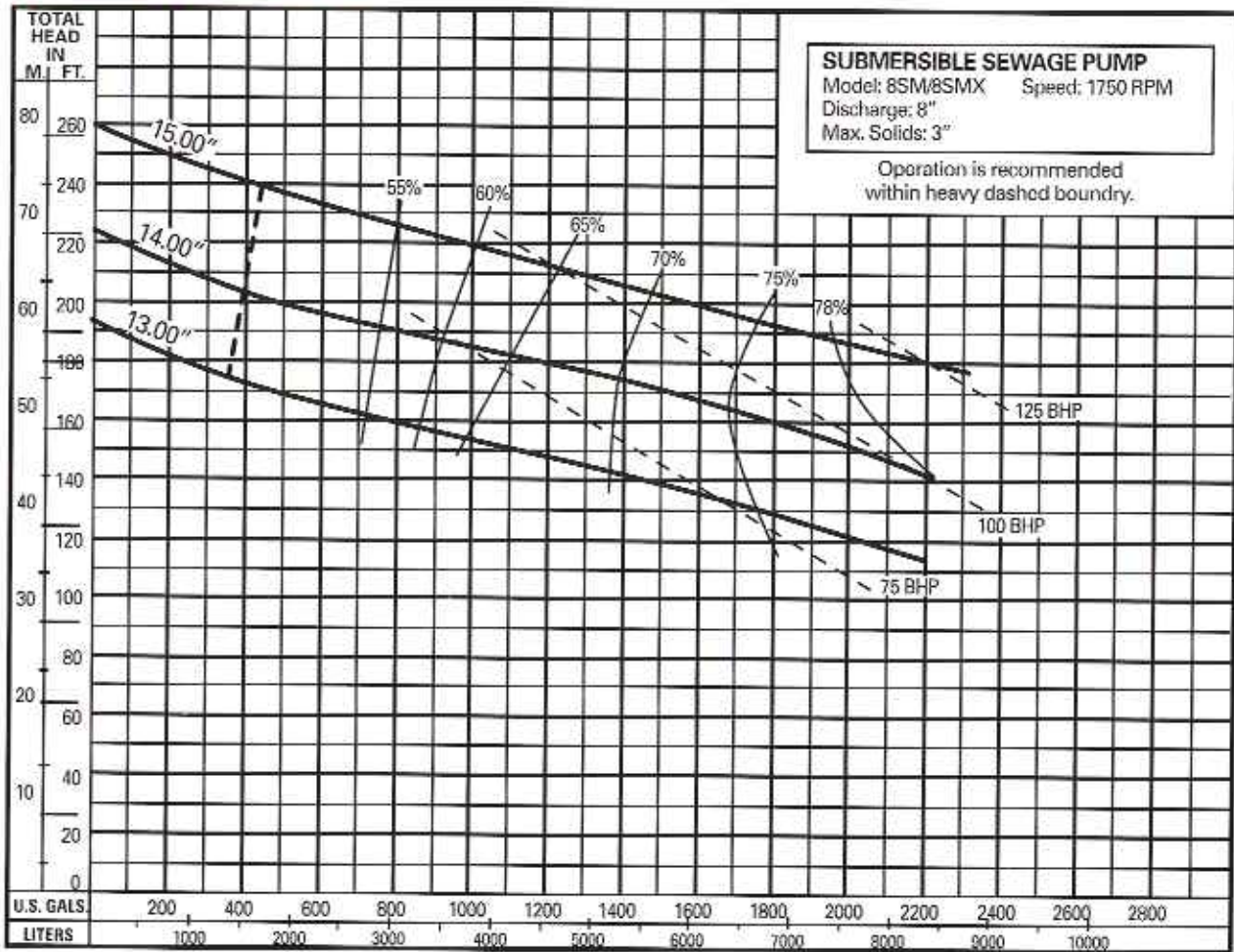

Available Models				Motor Electrical Data										
Standard	Explosion Proof	HP	Volts	Phase	Hz	Start Amps	Run Amps	Service Factor Amps	Run KW	Service Factor KW	Start KVA	Run KVA	NEC Code Letter	Service Factor
8SM750M4-43	8SMX750M4-43	75	460	3	60	540	101.8	122.2	64.2	77.0	430	81.0	G	1.2
8SM750M4-53	8SMX750M4-53	75	575	3	60	432	81.4	97.8	64.2	77.0	430	81.0	G	1.2
8SM1000M4-43	8SMX1000M4-43	100	460	3	60	725	129.0	155.0	85.7	103.0	578	103.0	G	1.2
8SM1000M4-53	8SMX1000M4-53	100	575	3	60	580	103.2	124.0	85.7	103.0	578	103.0	G	1.2
8SM1250M4-43	8SMX1250M4-43	125	460	3	60	725	165.0	175.0	108.0	115.0	578	131.0	G	1.1
8SM1250M4-53	8SMX1250M4-53	125	575	3	60	580	132.0	140.0	108.0	115.0	578	131.0	G	1.1

Motor Efficiencies and Power Factor									
		Motor Efficiency %				Power Factor %			
HP	Phase	Service Factor Load	100% Load	75% Load	50% Load	Service Factor Load	100% Load	75% Load	50% Load
75	3	87.1	87.1	87.3	83.5	79.1	79.2	79.1	79
100	3	87.0	88.0	87.0	84.0	83.4	83.4	79.2	77
125	3	86.0	86.3	88.0	87.0	82.5	82.0	80.0	78

CABLE ENTRY SYSTEM

Cable jackets sealed with clamped, rubber grommet. Individual wires sealed with epoxy to prevent wicking in case of cable damage.

TERMINAL BOARD

Provides easy connections from power and control cables to stator. Allows voltage change in field on dual winding motors.

HEAT SENSOR ON MOTOR WINDING

Opens to de-energize motor starter if winding temperature reaches 150°C. Automatic reset.

MOTOR STATOR

Oil-filled for continuous lubrication of bearings and seals. Class II insulation.

BALL BEARINGS

Upper and lower ball bearings.

HEAVY 416 SST SHAFT

Reduces deflection from impeller radial loads. Tapered and keyed to accept impeller.

DOUBLE TANDEM SHAFT SEALS

Protect motor, operate in clean oil.

HORIZONTAL DISCHARGE VOLUTE CASE
8" 125 lb. flange.

BRONZE WEAR RING

Reduces by-pass leakage and wear. Replaceable to restore original running clearances and pump efficiencies.

HIGH EFFICIENCY IMPELLER

Two-vane, rounded port, non-clogging design. Passes 3" spherical solids.

DUAL SEAL LEAK PROBES

Detect water in seal housing. Activates warning light in control panel.

PUMP OUT VANES

Help keep trash from seal, reduces pressure at seal faces.

DIMENSIONS

[] Dimensions in mm

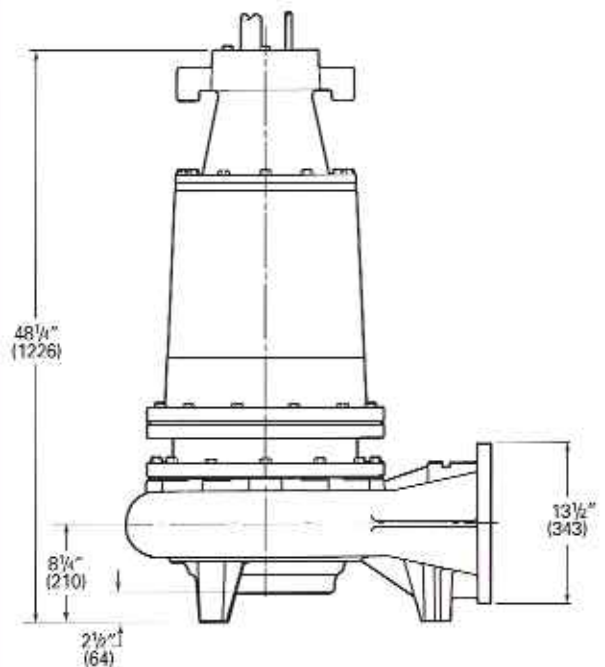
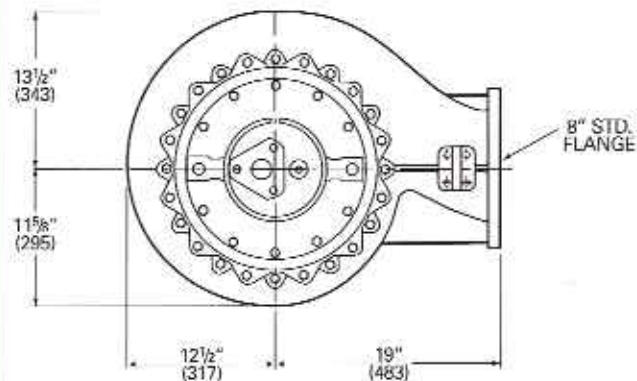

8SM and 8SMX

SPECIFICATIONS

PUMP MODEL - Pump shall be Myers Model Number 8SM / 8SMX Non-Clog Submersible Pump with 2 vane enclosed impeller. All openings in pump impeller and volute case to be large enough to pass a 3" diameter sphere. Discharge flange shall be eight (8) inch standard. The pump and motor assembly shall be FM listed for Class 1, Groups C and D explosion-proof service (8SMX only).

OPERATING CONDITIONS - Pump shall have a capacity of _____ GPM at a total head of _____ feet and shall use a _____ HP motor operating at _____ RPM.

MOTOR - Pump motor shall be of the sealed submersible type rated _____ HP at _____ RPM 60 Hertz. Motor shall be for three phase 460 volts _____ or 575 volts _____. Motor shall be NEMA B type.

Stator winding shall be of the open type with Class H insulation good for 180°C maximum temperature. Winding housing shall be filled with a clean high dielectric oil that lubricates bearings and seals and transfers heat from winding and rotor to outer shell. Air-filled motors which do not have the superior heat dissipating capabilities of oil-filled motors shall not be considered equal.

Motor shall have two heavy duty ball bearings to support pump shaft and take radial and thrust loads. Ball bearings shall be designed for 50,000 hours B-10 life. Stator shall be held in place by four (4) clamp rings on the upper end of the stator; each clamp ring shall be held by two (2) motor bolts.

A heat sensor thermostat shall be attached to and imbedded in the winding and be connected in series with the motor starter contactor coil to stop motor if temperature of winding is more than 302°F. Thermostat shall reset automatically when motor cools to safe operating temperature. Three heat sensors to be used on 3 phase motors. The common pump, motor shaft shall be of 416 stainless steel and shall be of tapered design.

SEALS - Motor shall be protected by two mechanical seals mounted in tandem with a seal chamber between the seals. Seal chamber shall be oil filled to lubricate seal face and to transmit heat from shaft to outer shell.

Seal faces shall be carbon and ceramic and lapped to a flatness of one light band. Lower seal faces shall be _____ carbide (optional).

A double electrode shall be mounted in the seal chamber to detect any water entering the chamber through the lower seal. Water in the chamber shall cause a red light to turn on at the control box. This signal shall not stop motor but shall act as a warning only, indicating service is required.

IMPELLER - The impeller shall be ductile iron and of the 2 vane non-clog enclosed type. Vane inlet tips shall be carefully rounded to prevent stringy material from catching in vanes. Impeller shall be dynamically balanced. Impeller to be driven by stainless steel shaft key and impeller held in place with lock screw and washer on a tapered shaft. Impeller and motor shall lift off of case as a unit without disturbing discharge piping.

PUMP CASE - The volute case shall be cast iron and have a flanged center line discharge. Discharge flange shall be eight (8) inch standard with bolt holes straddling center line. Bronze wear ring to be bolted into case for guiding impeller neck and to prevent corrosion freeze up. Wear ring to be held from rotating by locking with stainless steel screws in end of ring.

PUMP AND MOTOR CASTING - All castings shall be of high tensile cast iron and shall be treated with phosphate and chromate rinse. All fasteners shall be 302 stainless steel.

BEARING END CAP - Upper motor bearing cap shall be a separate casting for easy mounting and replacement.

POWER CABLES - Power cord and control cord shall be triple sealed. The power and control conductor shall be single strand sealed with epoxy potting compound and then clamped in place with rubber seal bushing to seal outer jacket against leakage and to provide for strain pull. A third sealing area shall be provided by a terminal board to separate the cable entry chamber from the motor chamber. Cords shall withstand a pull of 300 pounds to meet FM requirements.

Insulation of power and control cords shall be type SJOW/SJOW-A or SOOW. Both control and power cords shall have a green carrier ground conductor that attaches to motor frame.